

Peso y Dimensiones

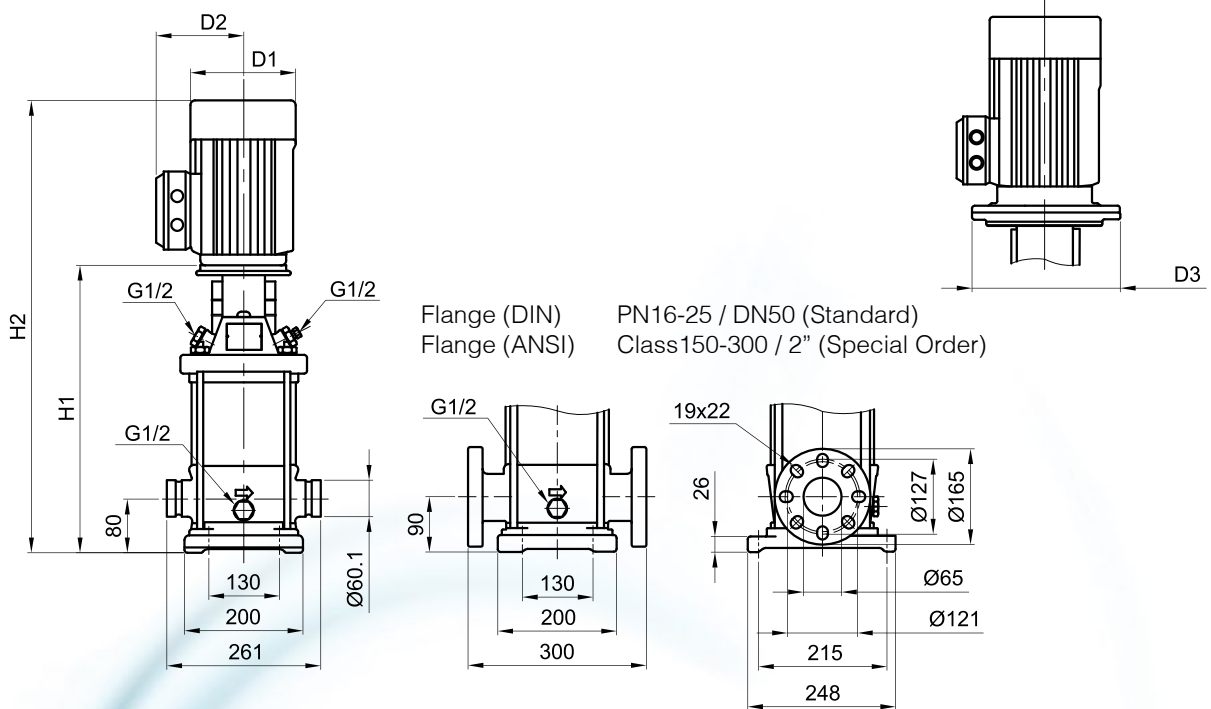

MODELO	HP	ACOPLE	DIMENSIONES Y PESO SERIE VPS - MOTORES IEC									PESO NETO	
			H1		H2		D1		D2				
			in	mm	in	mm	in	mm	in	mm	lbs	kg	
TRIFASICO													
VPS 15-1	2	90S	16 3/8	413	28	708	7	177	5 5/8	141	103	47	
VPS 15-2	4	100L	16 1/2	418	29	734	8	197	6	147	126	57	
VPS 15-3	5.5	112M	18 1/4	463	31 1/8	789	8 3/4	220	6 3/8	161	137	63	
VPS 15-4	7.5	132S	21 3/8	540	35 5/8	902	9 1/4	235	8	197	202	92	
VPS 15-5	10	132S	23 1/8	585	39	990	9 1/4	235	8	197	219	99	
VPS 15-6	15	160M	28	707	45 3/8	1152	10 5/8	269	8 1/2	215	292	132	
VPS 15-7	15	160M	29 5/8	752	47 1/8	1197	10 5/8	269	8 1/2	215	295	134	
VPS 15-8	15	160M	31 1/2	797	49	1242	10 5/8	269	8 1/2	215	298	135	
VPS 15-9	20	160M	33 1/4	842	52 1/2	1332	10 5/8	269	8 1/2	215	325	147	
VPS 15-10	20	160M	35	887	54 1/4	1377	10 5/8	269	8 1/2	215	328	149	
VPS 15-12	25	160L	38 1/2	977	59 3/4	1517	12 5/8	318	9 1/2	241	402	183	

Todas las medidas son de referencia. Los valores podrán cambiar según el modelo del motor.
 Todas las medidas y curvas de prestaciones son válidas para la serie VPC.